

INSTRUCTIONS FOR USE



Forano

gas outlet

CE⁰⁴⁸²

English

Forano gas outlet



Dear customers,

Thank you for purchasing this Greggersen product.

If you have any questions or require information, please contact our sales and support team.

Tel.: +49-(0)40 739357-0
e-mail: sales@greggersen.de



Please read the instructions for use thoroughly before using the medical device. Only use it once you have completely understood the application and function!

Medical device in
accordance with:

DIN EN ISO 9170-1
VMP 2017-745

Connections in
accordance with:

DIN 13260-2
BS 5682
NF S90-116
SS 875 24 30 (AGA)
SN ENV 737-6:2005 (Carbamed)

Preface

The Forano gas outlets from Greggersen Gasetechnik GmbH comply with the relevant provisions of Regulation (EU) 2017/745 of the European Parliament and Council (VMP 2017/745) and are classified as Class IIb active, non-invasive devices.

Basis UDI: 4031196FORANOESTAS

Intended use

To withdraw compressed gases and vacuum from a central medical gas supply system in accordance with DIN EN ISO 7396-1; designed to take low-pressure hose assemblies and medical appliances with plugs according to national standards.

Functionality

The gas outlets are intended to be connected to a gas supply system according to DIN EN ISO 7396-1 and to provide different types of compressed gases or vacuum. To withdraw the gases or vacuum, a plug must be connected to the gas outlet.

The plug is inserted into the gas outlet in the case of gas outlets compliant with the DIN, BS, AGA and Carbamed standards. The plug locks automatically and simultaneously establishes a connection to the gas or vacuum source by opening the sealing cone in the rear part. Once the application is finished, the plug can be released from the gas outlet by pressing the actuator, disconnecting the gas connection at the same time. In the case of the DIN gas outlets, the plug can be brought into the parking position by easy connection and disconnection. Here the plug is held in the gas outlet without a gas connection being established.

On the NF standard gas outlets, the plug must be locked with the union nut after it has been inserted into the gas outlet. To unlock, the plug must be pressed into the gas outlet while rotating the union nut. To permanently stop operation of the gas outlets, the sealing cone must be pressed into the gas outlet and screwed down. This seals the outlet point gas-tight and the front part can then be dismantled. In the DIN, AGA, BS and Carbamed versions, all sealing elements are located in a replaceable unit, the cartridge.

Warnings

- Prior to the use of the device, the user must be familiar with the product and the instructions for use and has to have understood them
- The gas outlet must be checked for external damage or contamination before each use. It must be ensured that the outlet unit is correctly aligned and that the labelling on the gas outlet is horizontal.
- When cleaning, make sure that no liquids enter the gas outlet. After cleaning, the gas outlet must be dried completely.
- Always keep all connections free of oil and grease!
Risk of fire!
- After installation or maintenance of the gas outlet, an acceptance check according to DIN EN ISO 7396-1 must be performed.
- Only use the gas outlet with plugs of the respective gas standard.
- Check the gas connection after connecting a DIN plug. The plug can be in the parking position.
- All serious incidents must be reported to Greggersen Gasetechnik GmbH and to the health authority responsible for the place of residence.



Our products are partly made of brass with a lead content of more than 0.1%. As an alloy component, lead is firmly bound in the material so that no exposure is to be expected.

Device description

Gas outlet DIN, DIN, BS, SN (Carbamed) SS (AGA)

No.	Description
1	Base block
2	Mounting screws
3	Sealing cone
4	Cartridge
5	Front part
6	Actuator

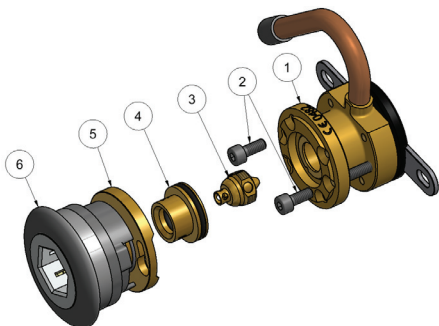

Gas outlet unit NF

No.	Description
1	Base block
2	Mounting screws
3	Sealing cone
4	O-ring
5	Front part
6	Pressure ring
7	Valve insert

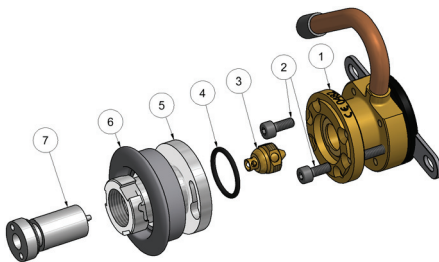

Patient target group

The gas outlets are used to provide medical gases or vacuum. The application of medical gases is determined by the medical personnel operating the gas outlet. Medical gases can be used for different purposes. No specific determination of the disease or condition, clinical form, stage, severity, symptoms or aspects to be treated/diagnosed is therefore possible.

Intended users

The medical device is intended for clinical use by medically qualified personnel (e.g. therapists, care personnel, doctors).

Operation

Before starting operation, an external visual inspection and a functional test have to be carried out each time.

During the external visual inspection, the gas outlet is checked for obvious damage or contamination. During the function test, however, the actuator is pressed to check the ease of movement.

To establish a gas or vacuum connection, a plug must be connected in the gas outlet. Please note that a parking position is also possible for DIN standard gas outlets. To bring a plug into the parking position, it is only inserted up to the first locking point. The gas connection has not yet been established in this position. To establish a gas connection, connect the plug up to the second locking point. NF standard plugs must be secured using the bayonet lock.

To release a plug, the actuator of the gas outlet must be pressed to pull the plug out of the gas outlet. In the case of DIN gas outlet, the plug can be moved to the parking position by simply pulling it beyond the first locking point. In case of NF standard gas outlets, the plug has to be pressed slightly into the gas outlet and the bayonet lock released.

Cleaning

The gas outlets can be wet cleaned with commercially available disinfectants and cleaning agents. When cleaning, make sure that no liquid enters the gas outlet. The gas outlet must be completely dry prior to subsequent use. The hygiene plan of the healthcare facility must be observed.

Installation

- Attach the base block depending on the type of installation.
- Solder the base block to the piping system.

Caution!

During soldering, the lines must be purged with inert gas.



- Attach the front panel depending on the type of installation.
- Place the front part of the gas outlet and screw it on.
- Click the actuator on.
- Establish the gas connection.

Caution!

After assembly, an acceptance test according to DIN EN ISO 7396-1 must be performed.

Installation may only be performed by trained personnel.



Maintenance and inspection

A function and tightness check according to DIN EN ISO 9170-1 must be carried out at least once a year.

Maintenance must be carried out at least every 6 years, whereby the cartridge has to be replaced. In case of intensive use, more frequent replacement of wearing parts may be necessary. Wear can lead to leaks and thus to audible hissing noises from the gas outlet. To replace the wearing parts, the sealing cone is screwed into the gas outlet with a 3 mm Allen key, which interrupts the gas flow. The actuator can then be pulled off and the front part removed by loosening the fixing screws. The cartridge is now accessible and can be changed. The front part then has to be reassembled and the gas flow opened.

On NF standard gas outlet, the valve insert must be changed, whereby the gas supply has to be interrupted.

On completion of maintenance work, an acceptance test according to DIN EN ISO 7396-1 must be carried out. Maintenance work may only be performed by trained personnel.

Technical data

Operating pressure: Compressed gases 400...500 kPa, max. 1000 kPa
vacuum \leq -40 kPa

Test pressure: Compressed gases max. 1500 kPa;
vacuum 500 kPa

Gas types: Oxygen (O₂), compressed air (AIR / MA),
vacuum (VAC), nitrous oxide (N₂O),
carbon dioxide (CO₂), nitrogen (N₂),
compressed air 800 (AIR-800 / SA), argon (Ar),
oxygen/nitrous oxide 50/50 (O₂/N₂O)

Standards: DIN, BS, SS (AGA), NF, SN (Carbamed)

Installation types: Concealed / hollow wall, surface-mounted,
rail mounting, ceiling supply units,
pipe at rear, straight pipe, barbed connector at
top, DVE-NIST, concealed barbed connector

Gas type identification: colour-neutral or according to ISO32

Temperature range: -20°C to +60°C

Maintenance parts

No.	Description
327463	Forano Cartridge DIN
327468	Forano Cartridge AGA
327477	Forano Cartridge Carba
325332	Forano Cartridge BS
326436	Forano Cartridge AGA Vac
326457	Cartridge conversion kit DIN - Forano II
103401	NF socket valve insert compressed gases
103402	NF socket valve insert vacuum
104785	NF socket valve insert AIR800



Accessories

No.	Description
903258	Forano front plate SU = 1 piece
903259	Forano front plate SU = 6 pieces
903309	Forano "not operative" sticker SU = 25 pieces
903380	Forano child safety lock AIR or O ₂
903381	Forano child safety lock CO ₂ / N ₂ O / VAC
903308	Key for Forano child safety lock
903302	Forano actuator disassembly tool
903301	Forano blind flange for pressure test
903300	Forano height adjustment assembly tool
903303	Forano mounting aid for placing 4 gas outlets
903304	Spanner for sealing cone retaining screw
903305	Forano sealing cone Allen key
326380	NF valve insert key compressed gases
326381	NF valve insert key VAC/AIR800
902114	Test kit gas outlets acc. to 7396-1/2 DIN
902128	Test kit gas outlets acc. to 7396-1/2 BS
902129	Test case gas outlet s acc. to 7396-1/2 AGA

Dimensions

Forano front part DIN

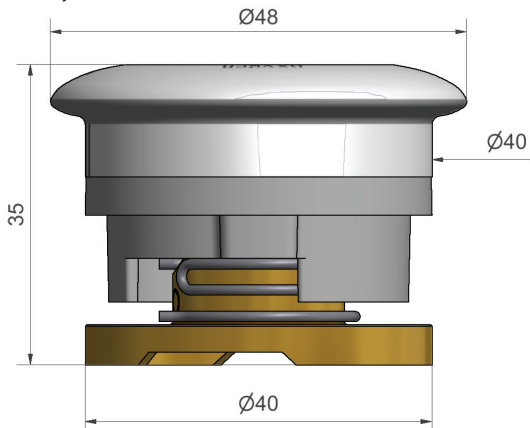

Forano front part Carbamed

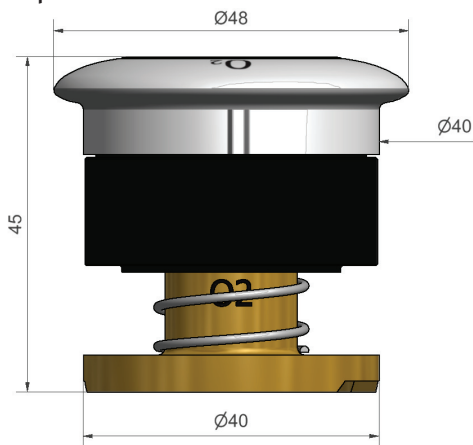

Forano front part SS (AGA)

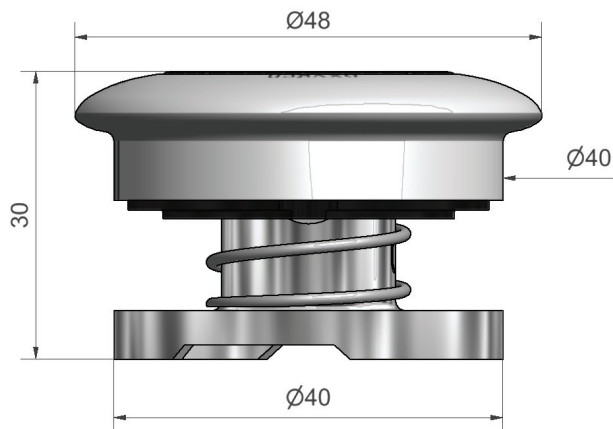

Forano front part BS

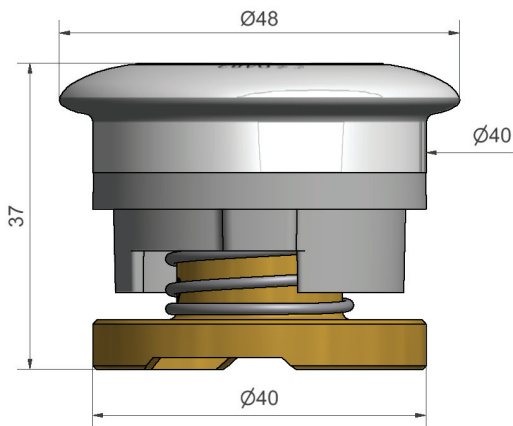

Forano front part NF

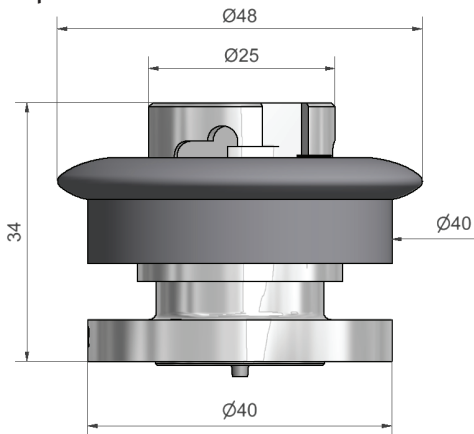

Forano front plate

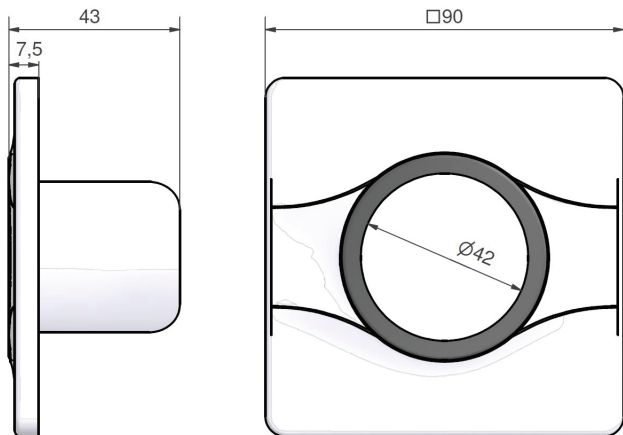

Forano rear part straight pipe up

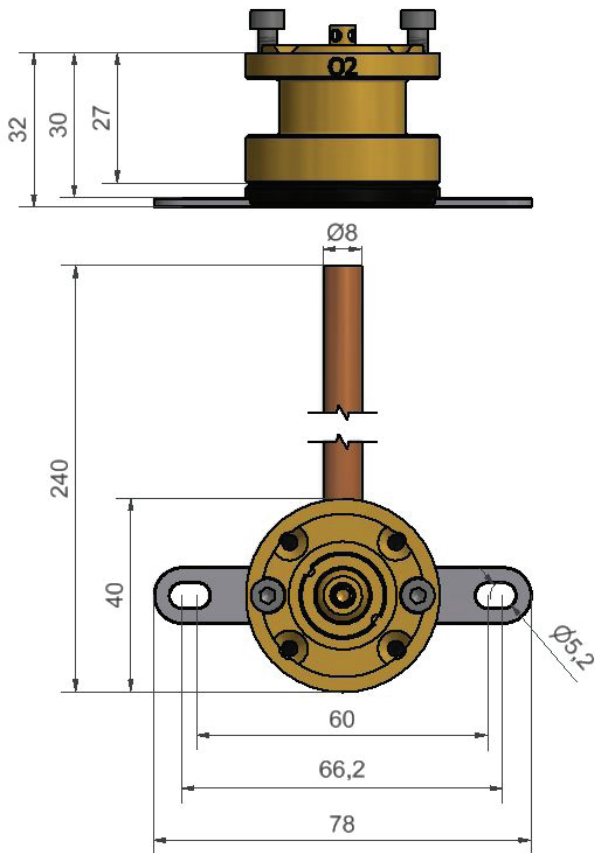

Forano rear part DVE

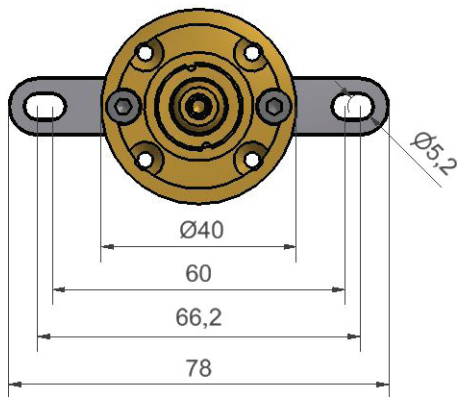
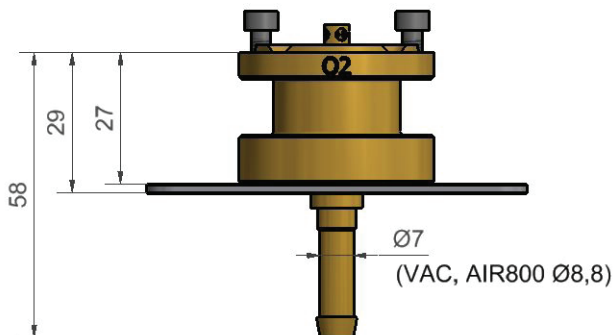

Forano rear part VS100M A right

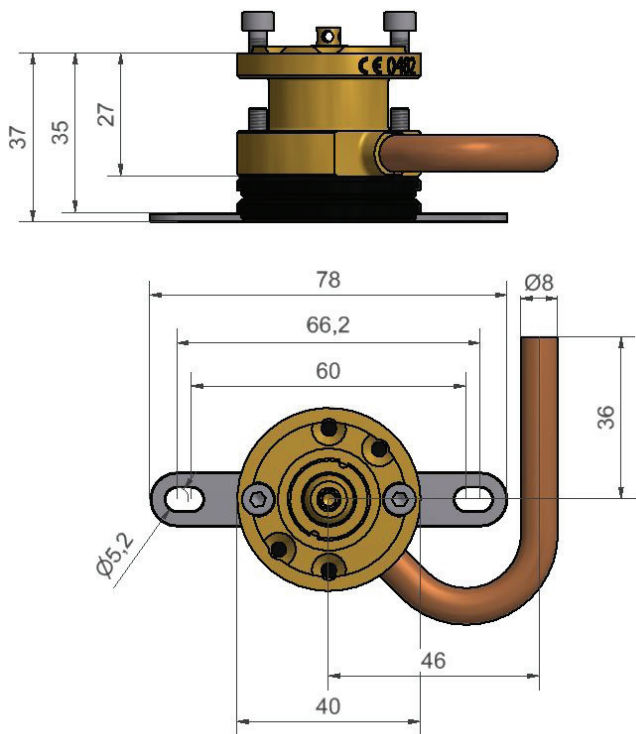

Forano rear part VS100M B left

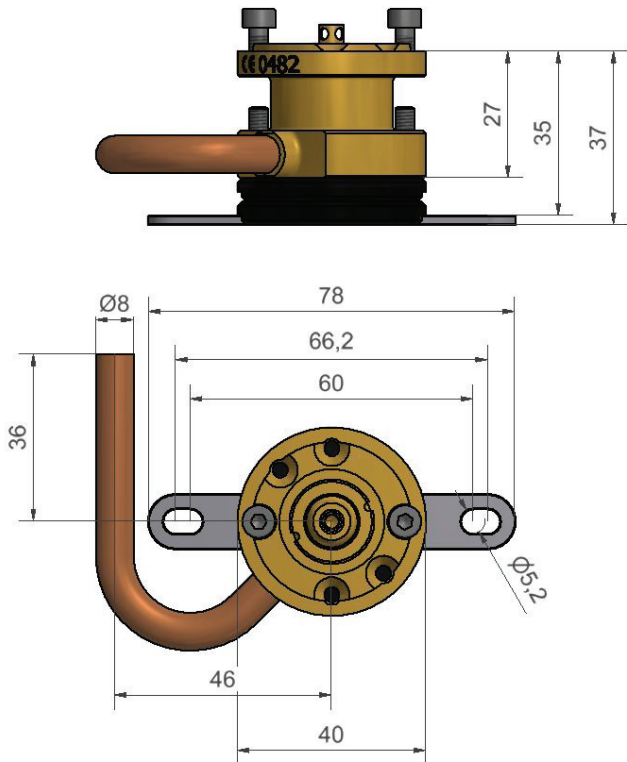

Forano rear part surface-mounted

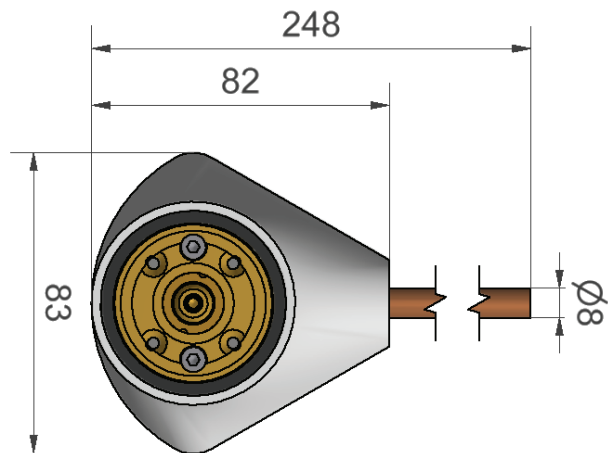

Forano rear part pipe at rear

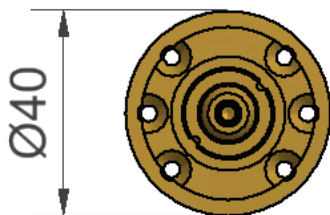
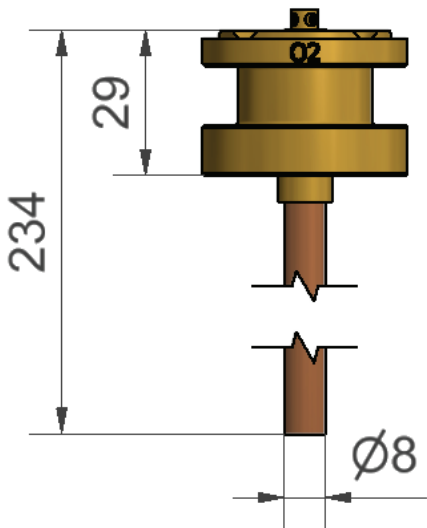

Forano rear part barbed connector top

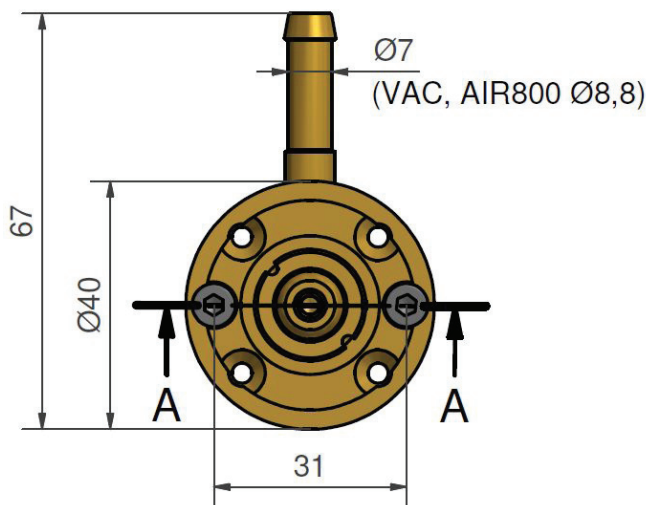
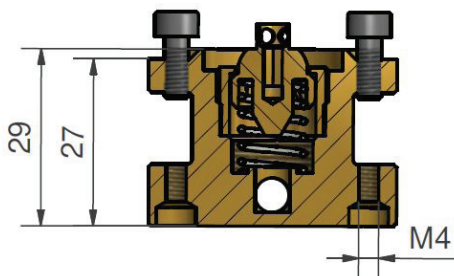

Forano rear part, concealed / hollow wall

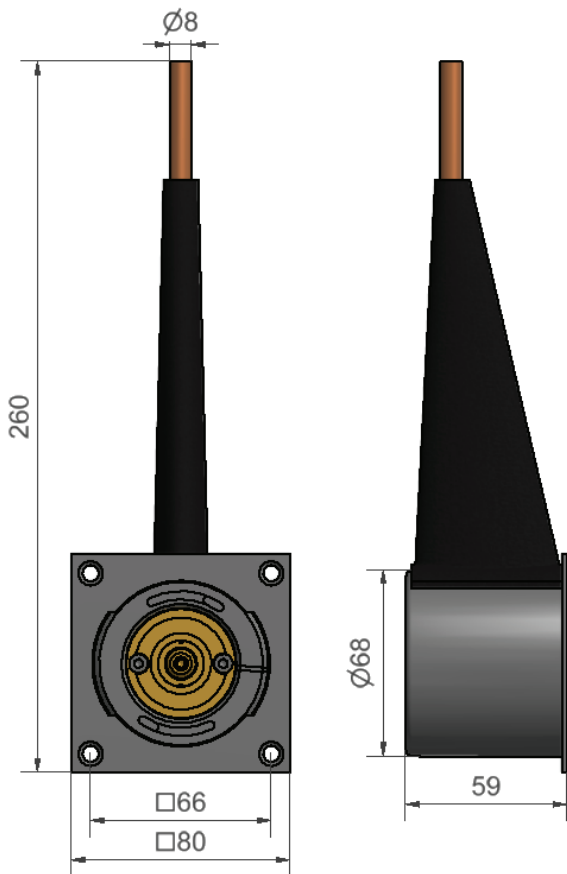

Notes:



www.greggersen.com

GREGGERSEN Gasetechnik GmbH / Bodestr. 27-29 / 21031 Hamburg / Germany

28.04.2021/M.Oels/106107-03 Doku Entnahmestelle Forano.en